

*Bluetooth*TM Module

EYSR2SXXX (Radio + Modem)

Specification report

In case you adopt this module and design some appliance,
Please ask for the latest specifications to the local sales
office.

EYSR2SXXX

TAIYOYUDEN Tentative

Document constituent list

Control name	Control No.	Document Page
General Items	HD-AG-A001109	1/1
Absolute maximum ratings	HD-AM-A001109	1/1
Electrical characteristics	HD-AE-A001109	1/3 -3/3
Circuit schematic	HC-MC-A001109	1/2-2/2
Outline / Appearance	HD-AD-A001109	1/2-2/2
Pin Layout	HD-BA-A001109	1/1
Reflow Profile		1/1

Rev. record

10-APR-2001> Newly issued

10-MAY-2001> Up-date

14-SEP-2001>Up-date

EYSR2SXXX

TAIYOYUDEN Tentative

Control No. HD-AG-A 001109	(1/1)	Control name General Items
-------------------------------	-------	-------------------------------

Scope

These specification apply to the hybrid IC “EYSR2SXXX” for use *Bluetooth*TM module by TAIYO YUDEN Co., Ltd.

1. Model Name:

EYSR2SXXX

2. Function: Radio frequency transfer Module (power class 2). *Bluetooth*TM standard Ver 1.1 conformity

3. Use: Note PC, PDA and Cellular Phone

4. Structure: Hybrid IC loaded with silicon monolithic semiconductor

5. Outline: 28 pin leadless chip carrier

6. Marking: Model name, Lot No. and manufacturer on Shielding Case

7. Packing:

Packaging method : Tray & aluminum moisture barrier bag

Packaging unit : 14*7=98 pieces/tray

Material of tray : PPE (Heat proof 135deg)

Tray Specification : JEDEC STD No. 95-1 Section 10 Revision C

8. Note:

- a. Any queries arisen to the specifications shall be solved by arrangement.
- b. Avoid use under the circumstance of radiation.
- c. The operating conditions for the guarantee of this product are as shown in the drawing for specifications. Please note that TAIYO YUDEN Co., Ltd. Shall be irresponsible for a failure and/ or abnormality which are caused by use under the conditions other than the aforesaid operating conditions.
- d. All electronic components listed in this catalog are developed, designed and intended for use in general electronics equipment (for AV, household, office supply, information service, telecommunications, etc.). Before using the components in any medical equipment, space equipment, disaster prevention equipment, etc. where higher safety and reliability are duly required the applicability and suitability of the electronics components must be fully evaluated to ensure correct operation in these type of specific conditions or installed in special equipment where a high concern for safety and reliability exist, evaluation of the safety function of the said components shall be thoroughly performed and when applicable a protective circuit shall be added in design stage.

This module is still under development, thus specifications do not guarantee both the quality and reliability at the time of shipment. Since the specifications and mass production of the module are not confirmed either, the contents of the technical notes are subject to change without any prior notice.

EYSR2SXXX

TAIYOYUDEN Tentative

Control No. HD-AM-A 001109	(1/1)	Control name Absolute maximum ratings
-------------------------------	-------	--

Absolute maximum ratings

Item	Symbol	Rating			Unit	Remark
		Min.	Typ	Max.		
Supply voltage	3V_A	-0.3		3.3	V	
	3V_D	-0.3		3.3		

Recommendation operating range

Item	Symbol	Rating			Unit	Remark
		Min.	Typ.	Max.		
Supply voltage	3V_A	2.7	3.0	3.3	V	
	3V_D	2.7	3.0	3.3		
Supply voltage ripple and spike noise	3V_A_ri			20	mVp-p	
	3V_D_ri			20		
Operation temperature range	Topr	0	25	70	degrees C	Humidity=40%RH Note 1

Note:

- 1.Operation temperature range is set to satisfy products electrical characteristics for a short period of time. Refer reliability, condition to check the product life cycle if you use this module for a long period of time in the condition other than the TYP standard.

EYSR2SXXX

TAIYOYUDEN Tentative

Control No. HD-AE-A 001109	(1/3)	Control name Electrical characteristics
-------------------------------	-------	--

Electrical characteristics

The Specification applies for Top=25°C,3V_A=3.0V,3V_D=3.0V

DC Specifications

No.	Parameter	Condition	Symbol	Spec			Unit	Remark
				Min	Typ	Max		
1	Peak Current	Transmit	I _t		45	65	mA	
		Receive	I _r		55	71	mA	
		Sleep	I _s		2		mA	Note
2	Logical Input High Voltage		V _{IH}	0.7x3V _D		3V _D	V	
3	Logical Input Low Voltage		V _{IL}	GND-0.1		0.2x3V _D	V	
4	Logical Output High Voltage		V _{OH}	0.8x3V _D		3V _D	V	
5	Logical Output Low Voltage		V _{OL}	GND		0.1x3V _D	V	
6	Logical Output High Current		I _{OH}			1	mA	
7	Logical Output Low Current		I _{OL}			1	mA	
8	Low-power output Voltage	I _{out} =10uA	V _{reg}	2.0		2.6	V	V _{BATT} = 2.7 to 4.8V
9	Output Absolute Max Current		I _{regm}			1	mA	

Note

Sleep Mode: /RM_RESET=Low, EN_CLK=Low

EYSR2SXXX

TAIYOYUDEN Tentative

Control No. HD-AE-A 001109	(2/3)	Control name Electrical characteristics
-------------------------------	-------	--

RF Specifications

<Transmitter Specification>

No.	Parameter	Condition	Symbol	Spec			Unit	Remark
				Min	Typ	Max		
1	Carrier Frequency Range		Freq.	2.402		2.480	GHz	
2	Frequency Tolerance	PN9 modulation	Df	-75		75	kHz	
3	RF Output Power	Z1=50ohm	Po	-6	-2	4	dBm	At maximum power output setting
4	Output Load VSWR	at 50ohm system	VSWR			5:1		No Damage
5	Inband Spurious Emission	20dBc	ISE1			1	MHz	
		2MHz offset	ISE2			-20	dBm	
		>3MHz offset	ISE3			-40	dBm	
6	Out of Band Spurious Emission	30MHz to 1GHz	OSE1			-36	dBm	
		1GHz to 12.75GHz	OSE2			-30	dBm	
		1.8GHz to 1.9GHz	OSE3			-47	dBm	
		5.15GHz to 5.3GHz	OSE4			-47	dBm	
7	Modulation characteristics	11110000	Δf_{1avg}	140	157	175	kHz	
		10101010	Δf_{2avg}	115		170	kHz	

EYSR2SXXX

TAIYOYUDEN Tentative

Control No. HD-AE-A 001109	(3/3)	Control name Electrical characteristics
-------------------------------	-------	--

<Receiver Specifications>

No.	Parameter	Condition	Symbol	Spec			Unit	Remark
				Min	Typ	Max		
1	RX Sensitivity	BER<0.1%	SEN		-80	-70	dBm	After Cal.
2	Maximum Input Level	Pin-max	MIP	-20	-15		dBm	
3	C/I	Co-Channel	CIC			14	dB	
		1MHz	CI1			0	dB	
		2MHz	CI2			-30	dB	
		=>3MHz	CI3			-40	dB	
4	Out of Band Blocking	30MHz to 2GHz	OBB1	-10			dBm	
		2GHz to 2.399GHz	OBB2	-27			dBm	
		2.498GHz to 3GHz	OBB3	-27			dBm	
		3GHz to 12.75GHz	OBB4	-10			dBm	
5	Intermodulation	F1=2437GHz F2=2434GHz	IMH	-39			dBm	
		F1=2443GHz F2=2446GHz	IML					
6	Spurious Emission	30MHz to 1GHz	RSE1			-57	dBm	
		1GHz to 12.75GHz	RSE2			-47	dBm	

EYSR2SXXX

TAIYOYUDEN Tentative

Control No. HD-MC-A 001109	(1/2)	Control name Circuit Schematic
-------------------------------	-------	-----------------------------------

Block Diagram

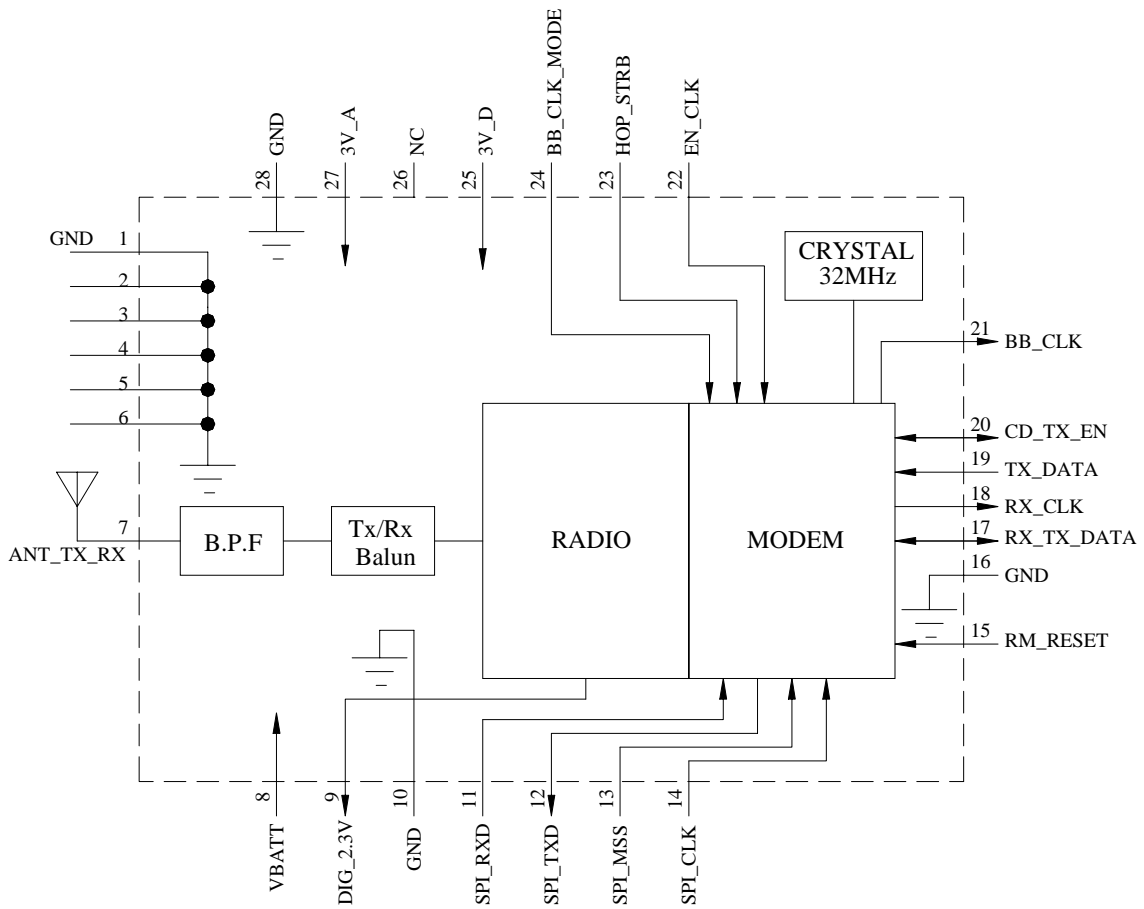

EYSR2SXXX

TAIYOYUDEN Tentative

Control No. HD-MC-A 001109	(2/2)	Control name Circuit Schematic
-------------------------------	-------	-----------------------------------

Sample Circuit

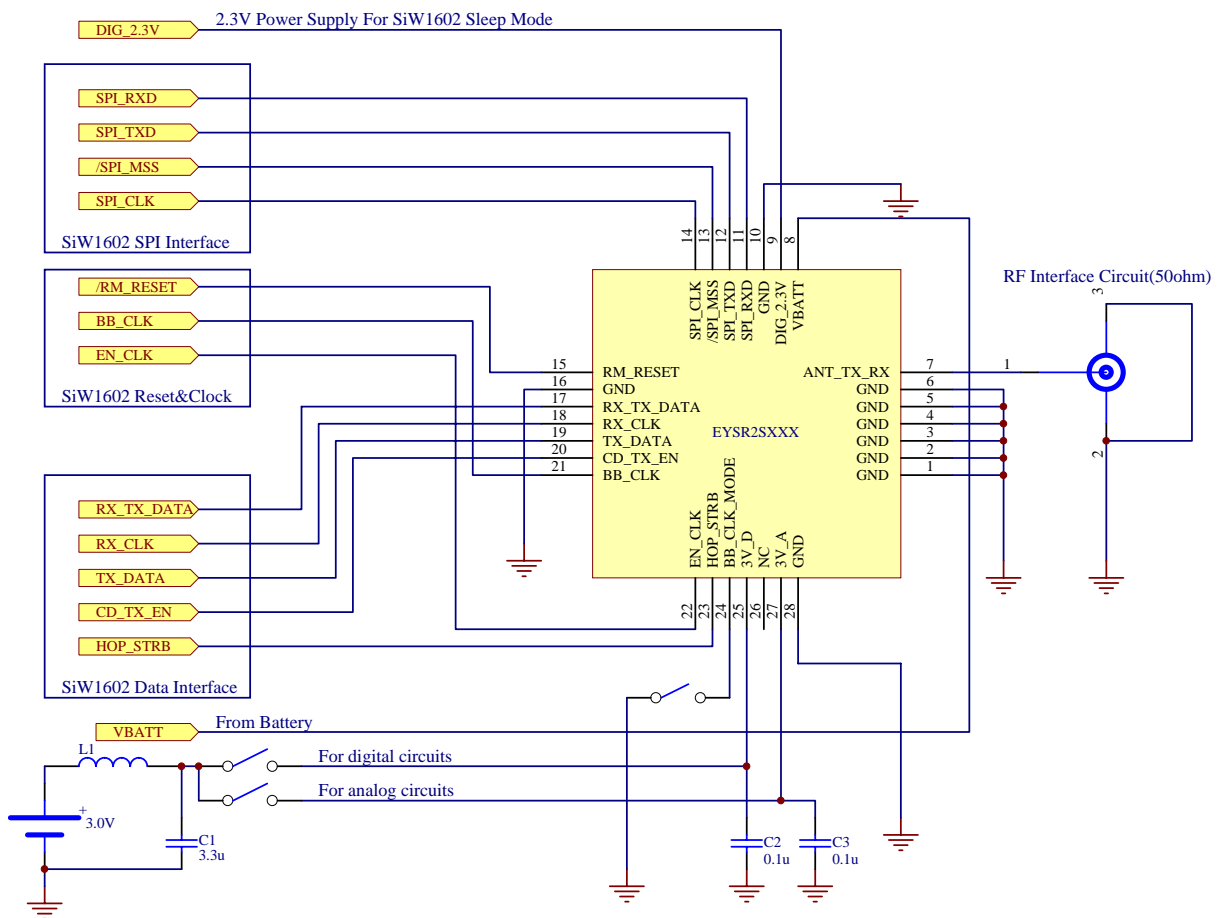

- L1: FBMH1608HM221 (TAIYO YUDEN CO.,LTD.)
- C1: LMK316BJ335K (TAIYO YUDEN CO.,LTD)
- C2,C3: UMK212BJ104K(TAIYO YUDEN CO.,LTD.)

EYSR2SXXX

TAIYOYUDEN Tentative

Control No. HD-AD-A 001109	(1/2)	Control name Outline/Appearance
-------------------------------	-------	------------------------------------

Unit:mm

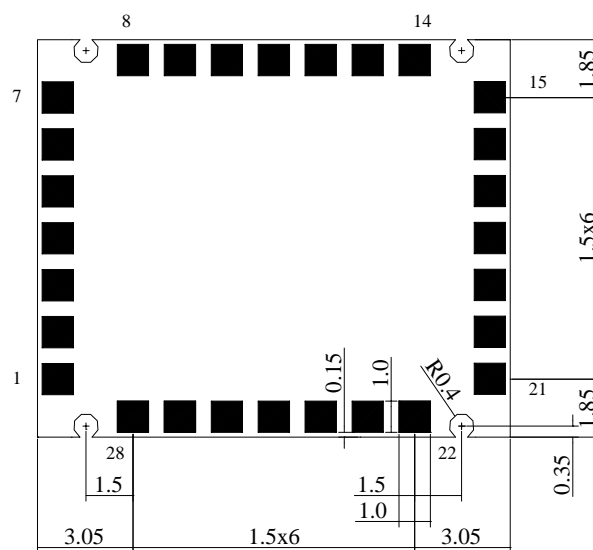
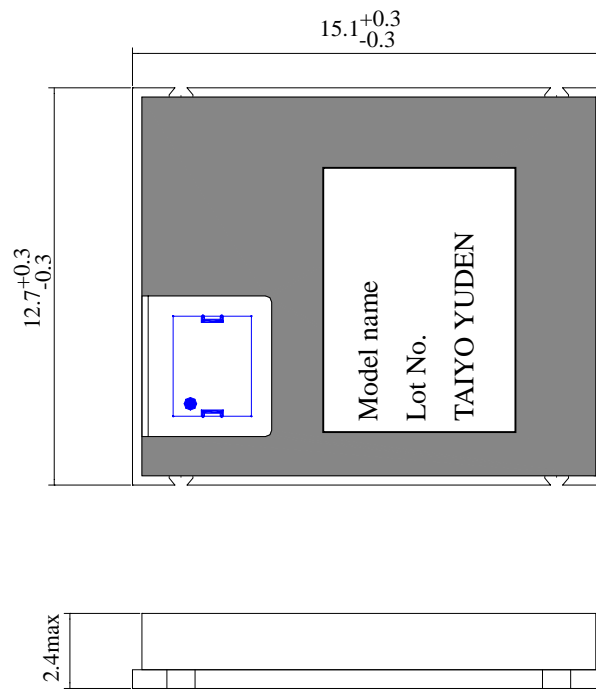

EYSR2SXXX

TAIYOYUDEN Tentative

Control No. HD-AD-A 001109	(2/2)	Control name Outline/Appearance
-------------------------------	-------	------------------------------------

LAND PATTERN EXAMPLE

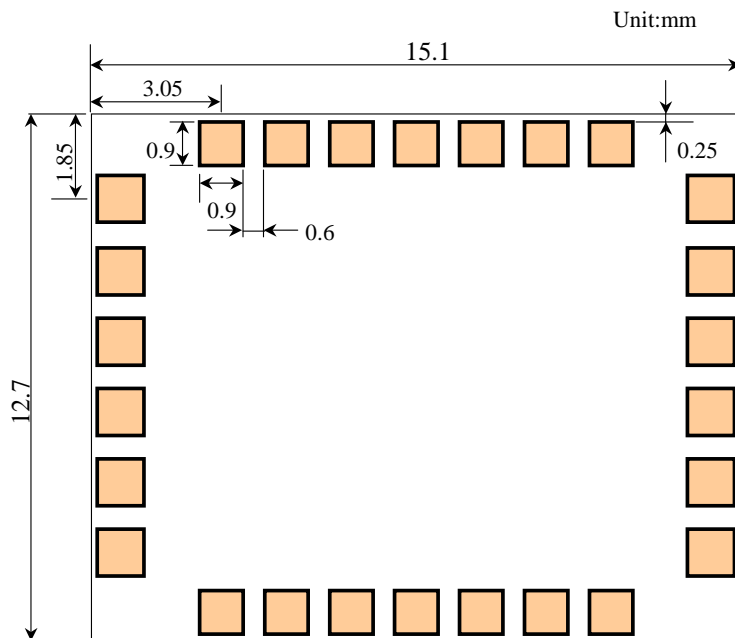

Caution

Do not wire on mother board except ground pattern where reverse side of module to be placed.

METAL MASK PATTERN EXAMPLE

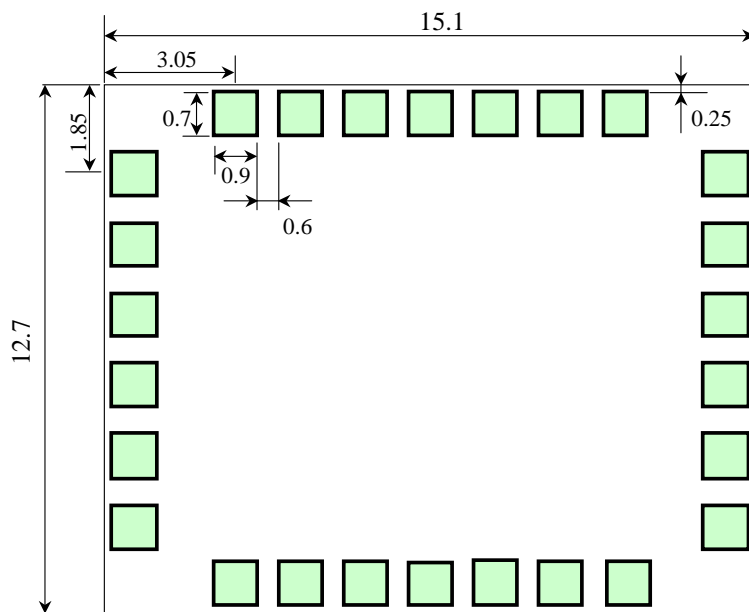

Thickness of Metal Mask t: 0.1 to 0.15mm

EYSR2SXXX

TAIYOYUDEN Tentative

Control No. HD-BA-A 001109	(1/1)	Control name Pin Layout
-------------------------------	-------	----------------------------

Pin Descriptions

No.	Pin Name	Type	Direction	Description	Block
1	GND	Power	Power	Ground	RF
2	GND	Power	Power	Ground	
3	GND	Power	Power	Ground	
4	GND	Power	Power	Ground	
5	GND	Power	Power	Ground	
6	GND	Power	Power	Ground	
7	ANT_TX_RX	RF	In/Out	50ohm Antenna connection	
8	VBATT	Power	Input	The on chip low power regulator input	Power Supply
9	DIG_2.3V	Power	Output	The on chip low power regulator output	
10	GND	Power	Power	Ground	SPI
11	SPI_RXD	CMOS	Input	SPI receive port	
12	SPI_TXD	CMOS	Output	SPI transmit port	
13	/SPI_MSS	CMOS	Input	Slave select input	
14	SPI_CLK	CMOS	Input	Clock input	
15	/RM_RESET	CMOS	Input	Reset for digital circuits only	
16	GND	Power	Power	Ground	
17	RX_TX_DATA	CMOS	In/Out	Receive/Transmit data	Power Supply
18	RX_CLK	CMOS	Output	Receive clock output	
19	TX_DATA	CMOS	Input	Transmit data	
20	CD_TX_EN	CMOS	In/Out	Carrier detect and Transmit enable	
21	BB_CLK	CMOS	Output	Clock output to Baseband circuits	
22	EN_CLK	CMOS	Input	Enables 32MHz oscillator	
23	HOP_STRB	CMOS	Input	Start of Tx or Rx ramp-up	
24	BB_CLK_MODE	CMOS	Input	Select baseband clock (16or8MHz) during system power up and before the internal clock control registers are set by software. "High": the BB_CLK will be set to 16MHz. "Low": the BB_CLK will be set to 8MHz.	
25	3V_D	Power	Power	Digital +3V supply input	
26	NC	NC	-		
27	3V_A	Power	Power	Analog +3V supply input	Power Supply
28	GND	Power	Power	Ground	

Note: The CMOS buffers are low voltage TTL compatible signals.

EYSR2SXXX

TAIYOYUDEN Tentative

Control No. (1/1)	Control name Reflow Profile
----------------------	--------------------------------

