

*Bluetooth*TM Module

EYSF1SSXX (RF+Baseband (Class 1) USB Interface)

Specification report

In case you adopt this module and design some appliance,
Please ask for the latest specifications to the local sales
office.

EYSF1SSXX

TAIYOYUDEN Tentative

Document constituent list

Control name	Control No.	Document Page
General Items	HD-AG-A991414	1/1
Absolute maximum ratings	HD-AM-A991414	1/1
Electrical characteristics	HD-AE-A991414	1/5 -5/5
Circuit schematic	HD-MC-A991414	1/2 -2/2
Outline / Appearance	HD-AD-A991414	1/2 -2/2
Pin Layout	HD-BA-A991414	1/1
Reflow profile		1/1

Rev. record

12-MAR-2001> Newly issued

8-MAY-2001> Up-date

30-AUG-2001> Up-date

4-SEP-2001> Up-date

EYSF1SSXX

TAIYOYUDEN Tentative

Control No. HD-AG-A 991414	(1/1)	Control name General Items
-------------------------------	-------	-------------------------------

Scope

These specification apply to the hybrid IC “EYSF1SSXX” for use **Bluetooth**™ module by TAIYO YUDEN Co., Ltd.

1. Model Name:

EYSF1SSXX (USB I/F Support)

2. Function: Radio frequency transfer Module (power class 1). **Bluetooth**™ standard Ver 1.1 conformity

3. Use: Note PC, PDA and Cellular Phone

4. Structure: Hybrid IC loaded with silicon monolithic and GaAs semiconductor

5. Outline: 18 pin leadless chip carrier

6. Marking: Model name, BD_ADDR, Lot No. and manufacturer on Shielding Case.

7. Features:

-**Bluetooth**™ 1.1 Qualified

-USB 1.1 Specification compatible

Full-Speed support

-USB Sideband signal

-Point-to-Multipoint (7 Slaves)

-Encryption

-Hold, Sniff Mode

-Supported Link Type : ACL

8. Packing:

Packaging method : Tray & aluminum moisture barrier bag

Packaging unit : 8*5=40 pieces/tray

Material of tray : PPE (Heat proof 135deg)

Tray Specification : JEDEC STD No. 95-1 Section 10 Revision C

9. Note:

a. Any queries arisen to the specifications shall be solved by arrangement.

b. Avoid use under the circumstance of radiation.

c. The operating conditions for the guarantee of this product are as shown in the drawing for specifications.

Please note that TAIYO YUDEN Co., Ltd. Shall be irresponsible for a failure and/ or abnormality which are caused by use under the conditions other than the aforesaid operating conditions.

d. All electronic components listed in this catalog are developed, designed and intended for use in general electronics equipment (for AV, household, office supply, information service, telecommunications, etc.).

Before using the components in any medical equipment, space equipment, disaster prevention equipment, etc. where higher safety and reliability are duly required the applicability and suitability of the electronics components must be fully evaluated to ensure correct operation in these type of specific conditions or installed in special equipment where a high concern for safety and reliability exist, evaluation of the safety function of the said components shall be thoroughly performed and when applicable a protective circuit shall be added in design stage.

This module is still under development, thus specifications do not guarantee both the quality and reliability at the time of shipment. Since the specifications and mass production of the module are not confirmed either, the contents of the technical notes are subject to change without any prior notice.

EYSF1SSXX

TAIYOYUDEN Tentative

Control No. HD-AM-A 991414	(1/1)	Control name Absolute maximum ratings
-------------------------------	-------	--

Absolute maximum ratings

Item	Symbol	Rating			Unit	Remark
		Min.	Typ.	Max.		
Supply voltage	VDD	-0.3		3.45	V	

Recommendation operating range

Item	Symbol	Rating			Unit	Remark
		Min.	Typ.	Max.		
Supply voltage	VDD	3.15	3.3	3.45	V	
Supply voltage ripple and spike noise	VDD_rn			20	mVp-p	
Operation temperature range	Topr	0	25	70	degrees C	Humidity=40%RH Note 1

Note:

1. Operation temperature range is set to satisfy products electrical characteristics for a short period of time. Refer reliability condition to check the product life cycle if you use this module for a long period of time in the condition other than the Typ. standard.

EYSF1SSXX

TAIYOYUDEN Tentative

Control No. HD-AE-A 991414	(1/5)	Control name Electrical characteristics
-------------------------------	-------	--

Electrical characteristics

DC Specifications

The Specification applies for Ta=0 to +70 degrees C, VDD=3.15 to 3.45V

No.	Parameter	Condition	Symbol	Min	Typ	Max	Unit	Remark
1	Normal supply voltage		VDD	3.15	3.3	3.45	V	
2	Input low voltage	D+,D-	VIL1	-		0.8	V	
3	Input low voltage	DETACH	VIL2	-0.3		0.56	V	
4	Input low voltage	BTM_ON	VIL3	0		0.2	V	
5	Input low voltage	/RESET	VIL4	0		0.6	V	Note 1
6	Input High voltage (driven)	D+,D-	VIH1	2.0		3.08	V	
7	Input High voltage	DETACH	VIH2	2.47		3.11	V	
8	Input High voltage	BTM_ON	VIH3	2.0		VDD	V	
9	Input High voltage	/RESET	VIH4	-		-	V	Note 1
10	Output low voltage	D+,D-	VOL1	-		0.3	V	
11	Output low voltage	WAKE_UP	VOL2	-		0.4	V	IOL=0.8mA
12	Output High voltage	D+,D-	VOH1	2.8		3.08	V	
13	Output High voltage	WAKE_UP	VOH2	2.31		3.08	V	IOH=-200uA
14	Peak current	Continuous Tx	Icp1		(100)	TBD	mA	
15	Average current1	Hold mode (Slave only)	Icca1		(50)		mA	
16	Average current2	Standby mode	Icca2		(0.4)		mA	
17	Average current3	Send DM1packet	Icca3		(65)		mA	
18	Average current4	Receive DM1packet	Icca4		(60)		mA	

Note:

1. /RESET signal must be driven by open drain. Please input low voltage or open.

EYSF1SSXX

TAIYOYUDEN Tentative

Control No. HD-AE-A 991414	(2/5)	Control name Electrical characteristics
-------------------------------	-------	--

AC Specifications

The Specification applies for Ta=0 to +70 degrees C, VDD=3.15 to 3.45V

No.	Parameter	Condition	Symbol	Min	Typ	Max	Unit	Remark
1	VDD Rise Time from 0V to 3.15V (see Notes 1)		t1			2	ms	
2	VDD 2.0V to BTM_ON 2.0V	VDD=>BTM_ON	t2	0			ms	Notes 3
3	/RESET High-Z to Module Ready		t3			600	ms	Notes 4
4	/RESET Pulse Width (see Notes 2)		t4	1			ms	
5	DETACH Low to USB_I/F Active		t5	0		1	ms	
6	DETACH High to USB_I/F High-Z		t6			1	ms	
7	DETACH High to WAKE_UP High		t7	1			s	
8	DETACH Low to WAKE_UP Low		t8			1	ms	
9	BTM_ON 0.2V to VDD 0.2V	VDD=>BTM_ON	t9	0			ms	Notes 3
10	BTM_ON High to /RESET High-Z		t10	0			ms	
11	/RESET Low to BTM_ON Low		t11	0			ms	
12	DETACH Low to BTM_ON Low		t12	0			ms	

Notes:

1. If t1 is not satisfied the rise time, input /RESET signal of 1ms or more in condition of VDD at over 3.15V and BTM_ON in “High”.
2. /RESET signal must be driven by open drain output. Pull-up resistor inside the Module is 1M ohm (Typ.). See the figure below.
3. Input voltage of BTM_ON pin should not exceed VDD voltage.
4. It may change due to the firmware version. See the figure below.

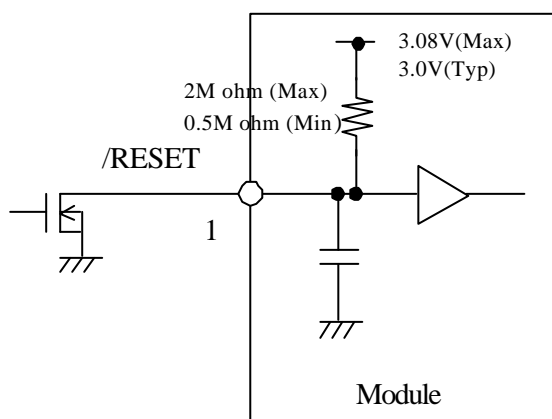

Equivalent Circuit of Internal Reset

EYSF1SSXX

TAIYOYUDEN Tentative

Control No. HD-AE-A 991414	(3/5)	Control name Electrical characteristics
-------------------------------	-------	--

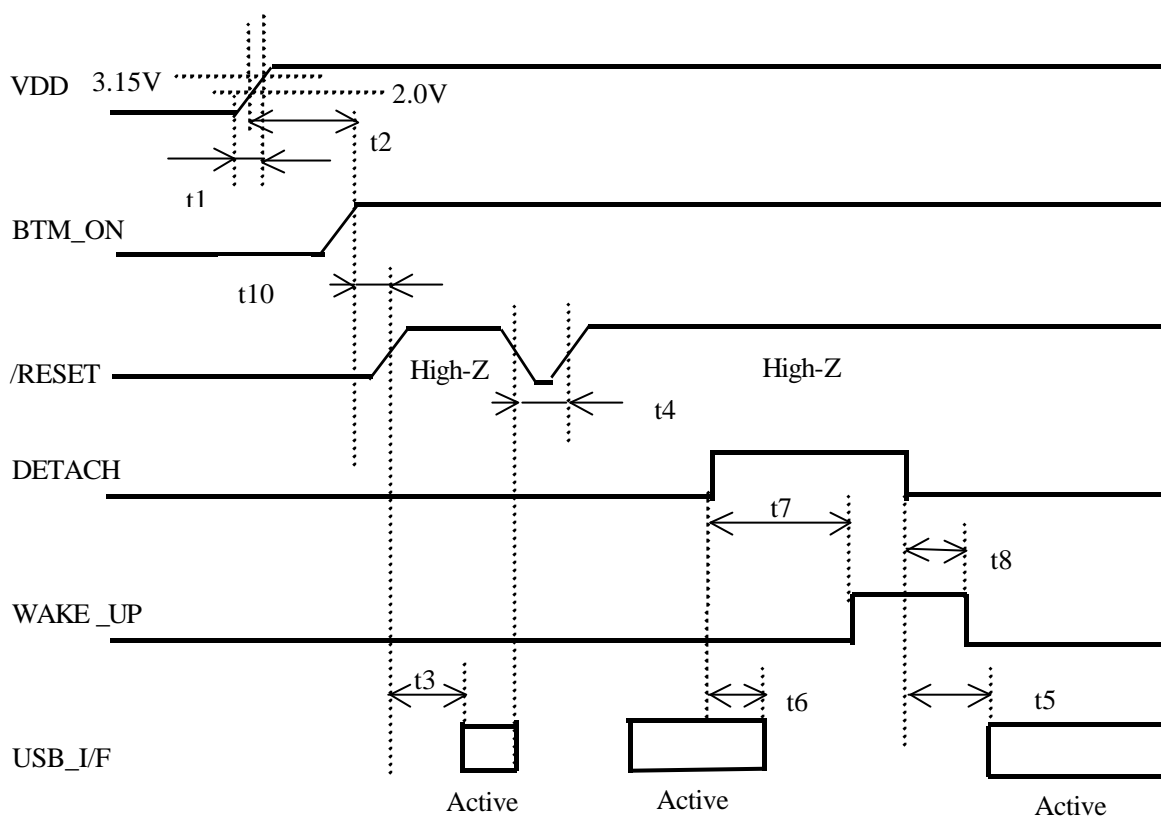

Timing Diagram for Power Up Sequence

EYSF1SSXX

TAIYOYUDEN Tentative

Control No. HD-AE-A 991414	(4/5)	Control name Electrical characteristics
-------------------------------	-------	--

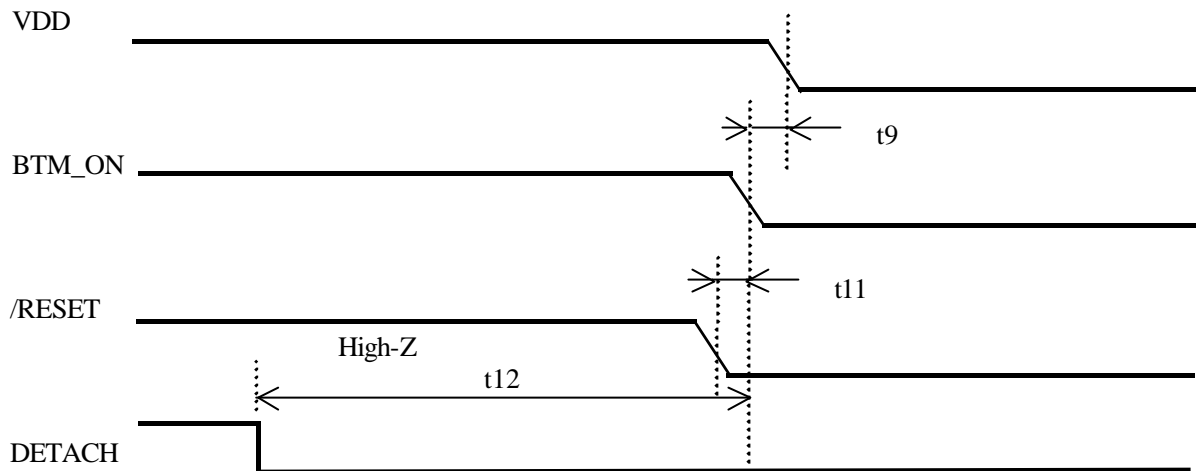

Timing Diagram for Power Down Sequence

EYSF1SSXX

TAIYOYUDEN Tentative

Control No. HD-AE-A 991414	(5/5)	Control name Electrical characteristics
-------------------------------	-------	--

RF Specifications

The Specification applies for Ta=25 degrees C, VDD=3.3V

No.	Parameter	Condition	Symbol	Min	Typ	Max	Unit	Remark
1	Frequency range		Freq.	2402		2480	MHz	
2	Tx power		P ₀		14	20	dBm	
3	Output Load VSWR	at 50 ohm System	VSWR			5:1		No Damage
4	Rx sensitivity		SEN		-75	-70	dBm	
5	C/I co-channel		CIC			14	dB	
6	C/I 1MHz		CI1			0	dB	
7	C/I 2MHz		CI2			-30	dB	
8	C/I >3MHz		CI3			-40	dB	
9	Out of band spurious1	30MHz to 1GHz	OSE1			-36	dBm	
10	Out of band spurious2	1 to 12.75GHz	OSE2			-30	dBm	

EYSF1SSXX

TAIYOYUDEN Tentative

Control No. HD-MC-A 991414	(1/2)	Control name Circuit Schematic
-------------------------------	-------	-----------------------------------

Block Diagram

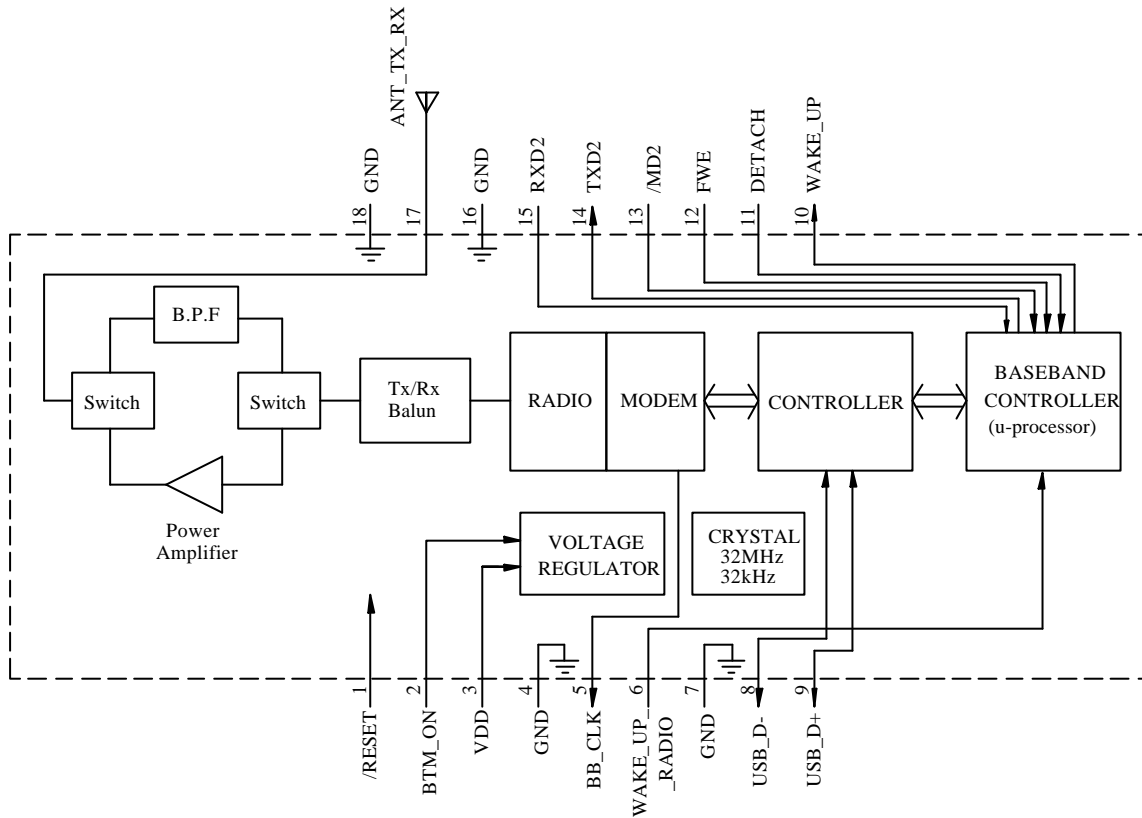

EYSF1SSXX

TAIYOYUDEN Tentative

Control No. HD-MC-A 991414	(2/2)	Control name Circuit schematic
-------------------------------	-------	-----------------------------------

Example of operating circuit

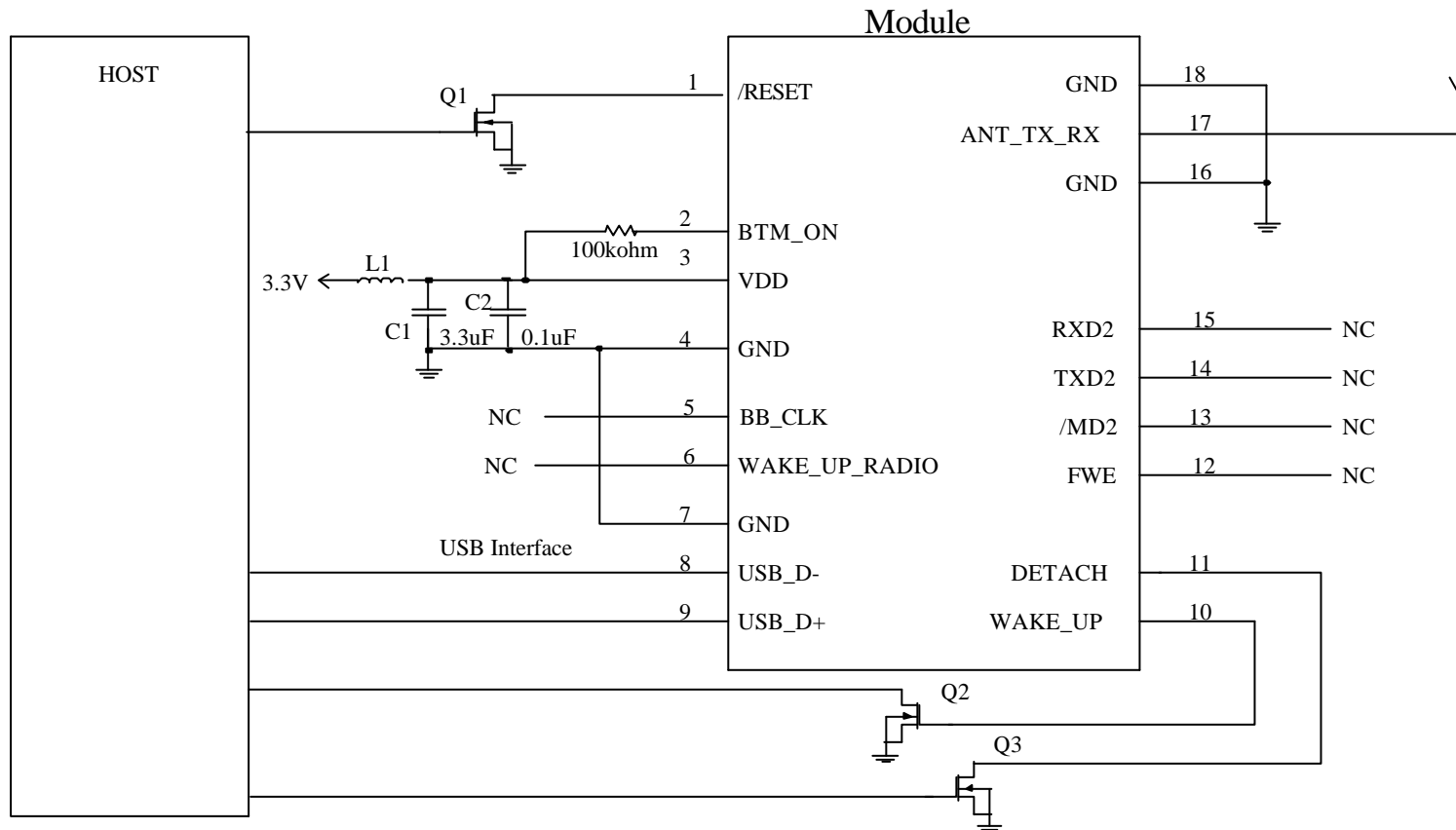

L1: FBMH1608HM221(TAIYO YUDEN CO.,Ltd.)
 C1: LMK316BJ335K(TAIYO YUDEN CO.,Ltd.)
 C2: UMK212BJ104K(TAIYO YUDEN CO.,Ltd.)
 Q1,Q2,Q3 : 2SK2158

TAIYO YUDEN

11/15

EYSF1SSXX

TYUDEN Tentative

Control No. HD-AD-A 991414	(1/2)	Control name Outline/Appearance
-------------------------------	-------	------------------------------------

Unit:mm

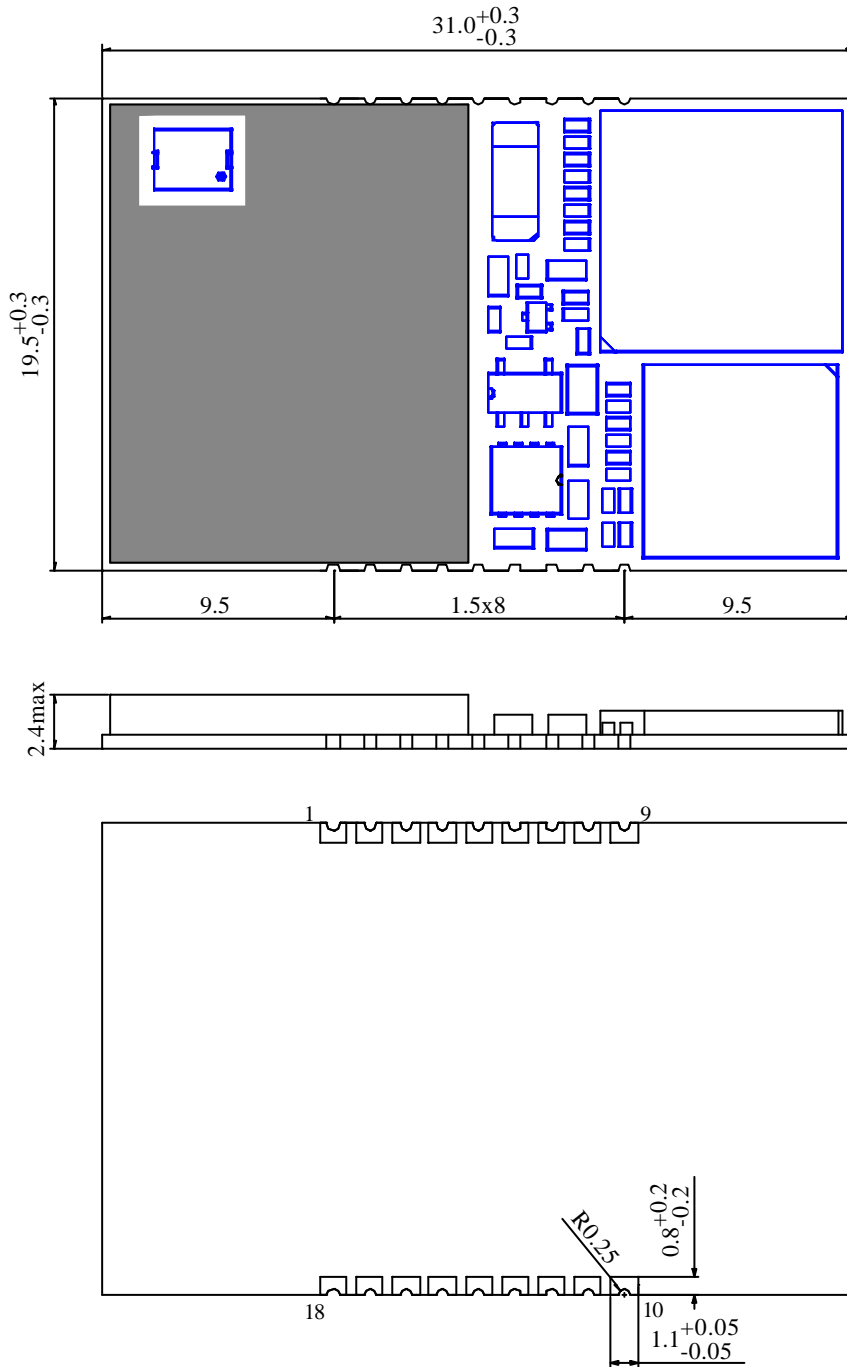

EYSF1SSXX

TYUDEN Tentative

Control No. HD-BA-A 991414	(1/1)	Control name Pin Layout
-------------------------------	-------	----------------------------

Pin Descriptions

No.	Pin Name	Type	Direction	Description	Block
1	/RESET	CMOS	Input	Active low reset, see note 3	
2	BTM_ON	CMOS	Input	When tied to VDD, the module is enabled.	
3	VDD	Power	Power	Power Supply Voltage	Power supply
4	GND	Power	Power	Signal ground	
5	BB_CLK	CMOS	Output	Do not connect -Baseband Clock Check port	
6	WAKE_UP_ RADIO	CMOS	Input	Do not connect	
7	GND	Power	Power	Signal ground	
8	USB_D-	CMOS	In/Out	USB data pin, see note 1	
9	USB_D+	CMOS	In/Out	USB data pin, see note 1	
10	WAKE_UP	CMOS	Output	Indicates that the module wants to be attached to the USB, active high, see note 2	USB
11	DETACH	CMOS	Input	Indicates that the USB host wants to detach the module, active high, see note 2	
12	FWE	CMOS	Input	Do not connect -Flash ROM write port	Flash ROM Write
13	/MD2	CMOS	Input	Do not connect -Flash ROM write port	
14	TXD2	CMOS	Output	Do not connect -Flash ROM write port	
15	RXD2	CMOS	Input	Do not connect -Flash ROM write port	
16	GND	Power	Power	Radio Frequency Ground	
17	ANT_TX_RX	RF	In/Out	50 ohm Antenna connection	RF
18	GND	Power	Power	Radio Frequency Ground	

Note: The CMOS buffers are low voltage TTL compatible signals.

Notes

- 1: Full-speed of USB 1.1 specification is supported. (D + line is internally pulled up by 1.5k ohm resistor.)
- 2: The output high voltage and input high voltage of these pins listed Pin 10 and Pin 11 is usually 3.0V. In case there is a mismatch of interface voltage between Host and our module, please use the level shift buffer or other proper way for these signals. When you don't use DETACH and WAKE_UP function, please connect DETACH pin to GND and open WAKE_UP pin.
- DETACH pin is internally pulled up toward 3.0V (Typ) or 3.08V (Max) by 100k ohm.
- 3: /RESET signal must be driven by open drain output. Pull-up resistor is not needed externally.

EYSF1SSXX

TYUDEN Tentative

Control No. (1/1)	Control name Reflow profile
----------------------	--------------------------------

