

# *Bluetooth*<sup>TM</sup> Module

EYSF2SAXX (RF+Baseband (Class 2) UART Interface)

Specification report

In case you adopt this module and design some appliance,  
Please ask for the latest specifications to the local sales  
office.

**EYSF2SAXX**

TAIYOYUDEN Tentative

## Document constituent list

Control name	Control No.	Document Page
General Items	HD-AG-A001111	1/1
Absolute maximum ratings	HD-AM-A001111	1/1
Electrical characteristics	HD-AE-A001111	1/4 -4/4
Circuit schematic	HC-MC-A001111	1/2 -2/2
Outline / Appearance	HD-AD-A001111	1/2 -2/2
Pin Layout	HD-BA-A001111	1/1
Reflow profile		1/1

## Rev. recorde

7-MAR-2001&gt; Newly issued

12-MAR-2001&gt; Up-date

8-MAY-2001&gt; Up-date

10-JUL-2001&gt; Up-date

3-SEP-2001&gt; Up-date

**EYSF2SAXX**

TAIYOYUDEN Tentative

Control No. HD-AG-A 001111 (1/1)	Control name General Items
-------------------------------------	-------------------------------

## Scope

These specification apply to the hybrid IC "EYSF2SAXX" for use **Bluetooth**™ module by TAIYO YUDEN Co., Ltd.

## 1. Model Name:

EYSF2SAXX (UART I/F Support)

2. Function: Radio frequency transfer Module (power class 2). **Bluetooth**™ standard Ver 1.1 conformity

## 3. Use: Note PC, PDA and Cellular Phone

## 4. Structure: Hybrid IC loaded with silicon monolithic semiconductor

## 5. Outline: 24 pin leadless chip carrier

## 6. Marking: Model name, BD\_ADDR, Lot No. and manufacturer on Shielding Case.

## 7. Features:

-**Bluetooth**™ 1.1 Qualified

-UART Interface

Baud Rate : 115.2kbps

-Point-to-Multipoint (7 Slaves)

-Encryption

-Hold, Sniff Mode

-Sleep Mode

-Supported Link Type : ACL

## 8. Packing:

Packaging method : Tray & aluminum moisture barrier bag

Packaging unit : 8\*6=48 pieces/tray

Material of tray : PPE (Heat proof 135deg)

Tray Specification : JEDEC STD No. 95-1 Section 10 Revision C

## 9. Note:

a. Any queries arisen to the specifications shall be solved by arrangement.

b. Avoid use under the circumstance of radiation.

c. The operating conditions for the guarantee of this product are as shown in the drawing for specifications. Please note that TAIYO YUDEN Co., Ltd. Shall be irresponsible for a failure and/ or abnormality which are caused by use under the conditions other than the aforesaid operating conditions.

d. All electronic components listed in this catalog are developed, designed and intended for use in general electronics equipment (for AV, household, office supply, information service, telecommunications, etc.). Before using the components in any medical equipment, space equipment, disaster prevention equipment, etc. where higher safety and reliability are duly required the applicability and suitability of the electronics components must be fully evaluated to ensure correct operation in these type of specific conditions or installed in special equipment where a high concern for safety and reliability exist, evaluation of the safety function of the said components shall be thoroughly performed and when applicable a protective circuit shall be added in design stage.

This module is still under development, thus specifications do not guarantee both the quality and reliability at the time of shipment. Since the specifications and mass production of the module are not confirmed either, the contents of the technical notes are subject to change without any prior notice.

**EYSF2SAXX**

TAIYOYUDEN Tentative

Control No. HD-AM-A 001111	(1/1)	Control name Absolute maximum ratings
-------------------------------	-------	--

## Absolute maximum ratings

Item	Symbol	Rating			Unit	Remark
		Min.	Typ.	Max.		
Supply voltage	VDD	-0.3		5.5	V	

## Recommendation operating range

Item	Symbol	Rating			Unit	Remark
		Min.	Typ.	Max.		
Supply voltage	VDD	3.15	3.3	5.5	V	
Supply voltage ripple and spike noise	VDD_rn			20	mVp-p	
Operation temperature range	Topr	0	25	70	degrees C	Humidity=40%RH Note 1

## Note:

- 1.Operation temperature range is set to satisfy products electrical characteristics for a short period of time.  
Refer reliability condition to check the product life cycle if you use this module for a long period of time in the condition other than the Typ. standard.

**EYSF2SAXX**

TAIYOYUDEN Tentative

Control No. HD-AE-A 001111	(1/4)	Control name Electrical characteristics
-------------------------------	-------	--

Electrical characteristic

## DC Specifications

The Specification applies for Ta=0 to +70 degrees C, VDD=3.15 to 5.5V

No.	Parameter	Condition	Symbol	Min	Typ	Max	Unit	Remark
1	Normal supply voltage		VDD	3.15	3.3	5.5	V	
2	Input low Voltage	RX, CTS, DSR	VIL1	-0.3		0.56	V	
3	Input low Voltage	BTM_ON	VIL2	0		0.2	V	
4	Input low Voltage	/RESET	VIL3	0		0.6	V	Note 1
5	Input High Voltage	RX, CTS, DSR	VIH1	2.47		3.11	V	
6	Input High Voltage	BTM_ON	VIH2	2.0		VDD	V	
7	Input High Voltage	/RESET	VIH3	-		-	V	Note 1
8	Output low voltage	TX,RTS,DTR	VOL	-		0.4	V	IOL=0.8mA
9	Output High voltage	TX,RTS,DTR	VOH	2.31		3.08	V	IOH=-200uA
10	Peak current	Continuous Rx	Iccp1		80	120	mA	
11	Average current1	Hold mode (Slave only)	Icca1		(51)		mA	
12	Average current2	Standby mode	Icca2		0.8		mA	
13	Average current3	Send DM1packet	Icca3		56		mA	
14	Average current4	Receive DM1packet	Icca4		61		mA	

Note:

1. /RESET signal must be driven by open drain output. Please input low voltage or open.

# EYSF2SAXX

TAIYOYUDEN Tentative

Control No. HD-AE-A 001111	(2/4)	Control name Electrical characteristics
-------------------------------	-------	--

## AC Specifications

The Specification applies for Ta=0 to +70 degrees C, VDD=3.15 to 5.5V

No.	Parameter	Condition	Symbol	Min	Typ	Max	Unit	Remark
1	VDD Rise Time from 0V to 3.15V (see Notes 1)		t1			2	ms	
2	VDD 2.0V to BTM_ON 2.0V		t2	0		0	ms	Notes 3
3	/RESET High-Z to Module Ready		t3			600	ms	Notes 4
4	/RESET Pulse Width (see Notes 2)		t4	1			ms	
5	BTM_ON 0.2V to VDD 0.2V		t5	0		0	ms	Notes 3
6	BTM_ON High to /RESET High-Z		t6	0			ms	
7	/RESET Low to BTM_ON Low		t7	0			ms	

### Notes:

1. If t1 is not satisfied the rise time, input /RESET signal of 1ms or more in condition of VDD at over 3.15V and BTM\_ON in “High”.
2. /RESET signal must be driven by open drain output. Pull-up resistor inside the Module is 1M ohm (Typ.). See the figure below.
3. Input voltage of BTM\_ON pin should not exceed VDD voltage.
4. It may change due to the firmware version. See the figure below.

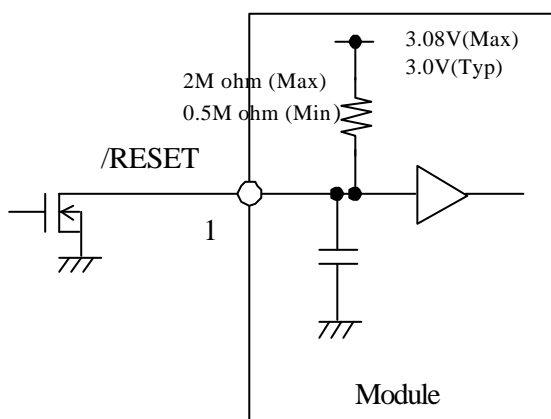

Equivalent Circuit of Internal Reset

# EYSF2SAXX

TAIYOYUDEN Tentative

Control No. HD-AE-A 001111	(3/4)	Control name Electrical characteristics
-------------------------------	-------	--

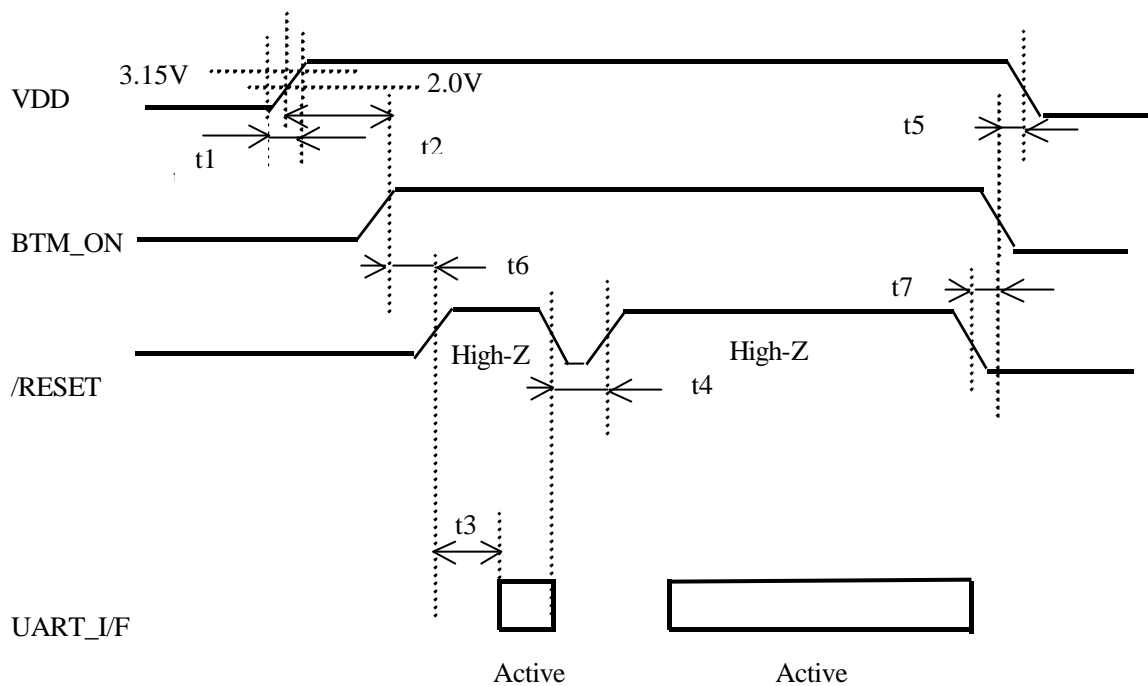

Timing Diagram for Power Up and Down Sequence

**EYSF2SAXX**

TAIYOYUDEN Tentative

Control No. HD-AE-A 001111	(4/4)	Control name Electrical characteristics
-------------------------------	-------	--

## RF Specifications

The Specification applies for Ta=25 degrees C, VDD=3.3V

No.	Parameter	Condition	Symbol	Min	Typ	Max	Unit	Remark
1	Frequency range		Freq.	2402		2480	MHz	
2	Tx power		P <sub>0</sub>	-6	-2	+4	dBm	
3	Output Load VSWR	at 50 ohm system	VSWR			5:1		No Damage
4	Rx sensitivity		SEN		-80	-70	dBm	
5	C/I co-channel		CIC			14	dB	
6	C/I 1MHz		CI1			0	dB	
7	C/I 2MHz		CI2			-30	dB	
8	C/I >3MHz		CI3			-40	dB	
9	Out of band spurious1	30MHz to 1GHz	OSE1			-36	dBm	
10	Out of band spurious2	1 to 12.75GHz	OSE2			-30	dBm	

## UART Parameters

Item	Parameter
Baud Rate	115.2kbps, see Note
Data Bits	8bits
Stop Bits	1bit
Parity	None
Flow Control	CTS/RTS

## Note:

You can also select the Baud Rate , 1Mbps, for the different model EYSF2SAAX. You may contact us for other Baud Rate.

# EYSF2SAXX

TAIYOYUDEN Tentative

Control No. HD-MC-A 001111	(1/2)	Control name Circuit Schematic
-------------------------------	-------	-----------------------------------

## Block Diagram

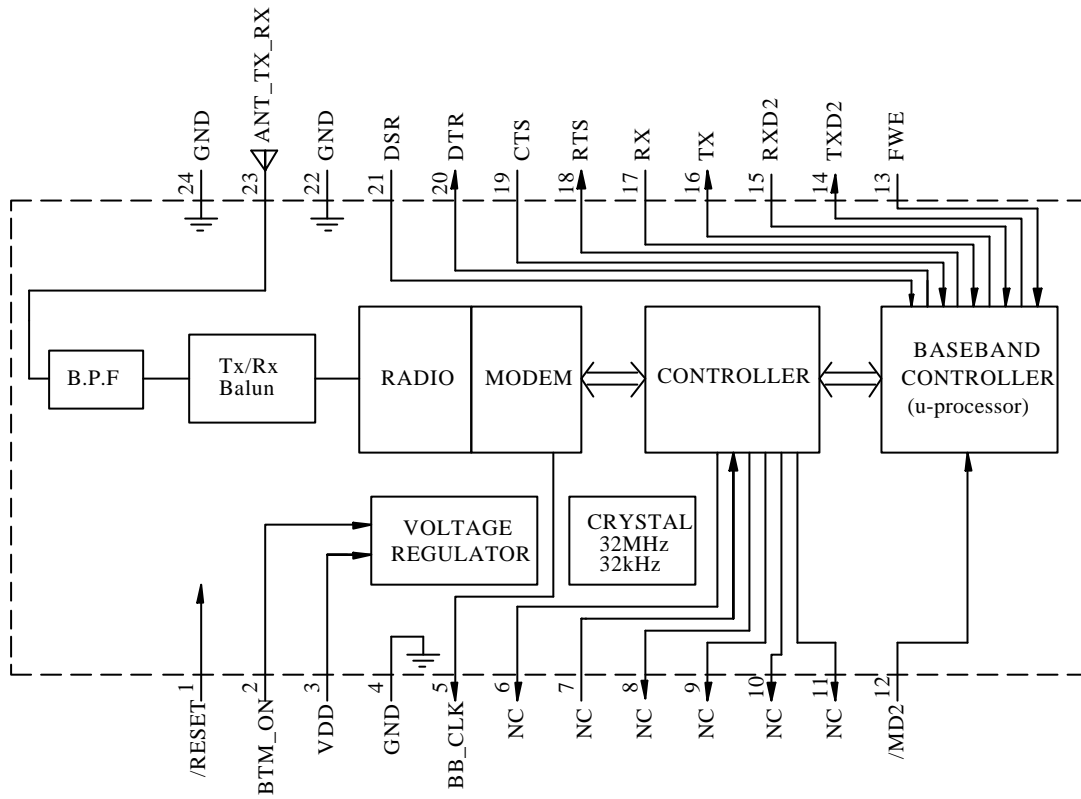

# EYSF2SAXX

TAIYOYUDEN Tentative

Control No. HD-MC-A 001111	(2/2)	Control name Circuit schematic
-------------------------------	-------	-----------------------------------

Example of operating circuit

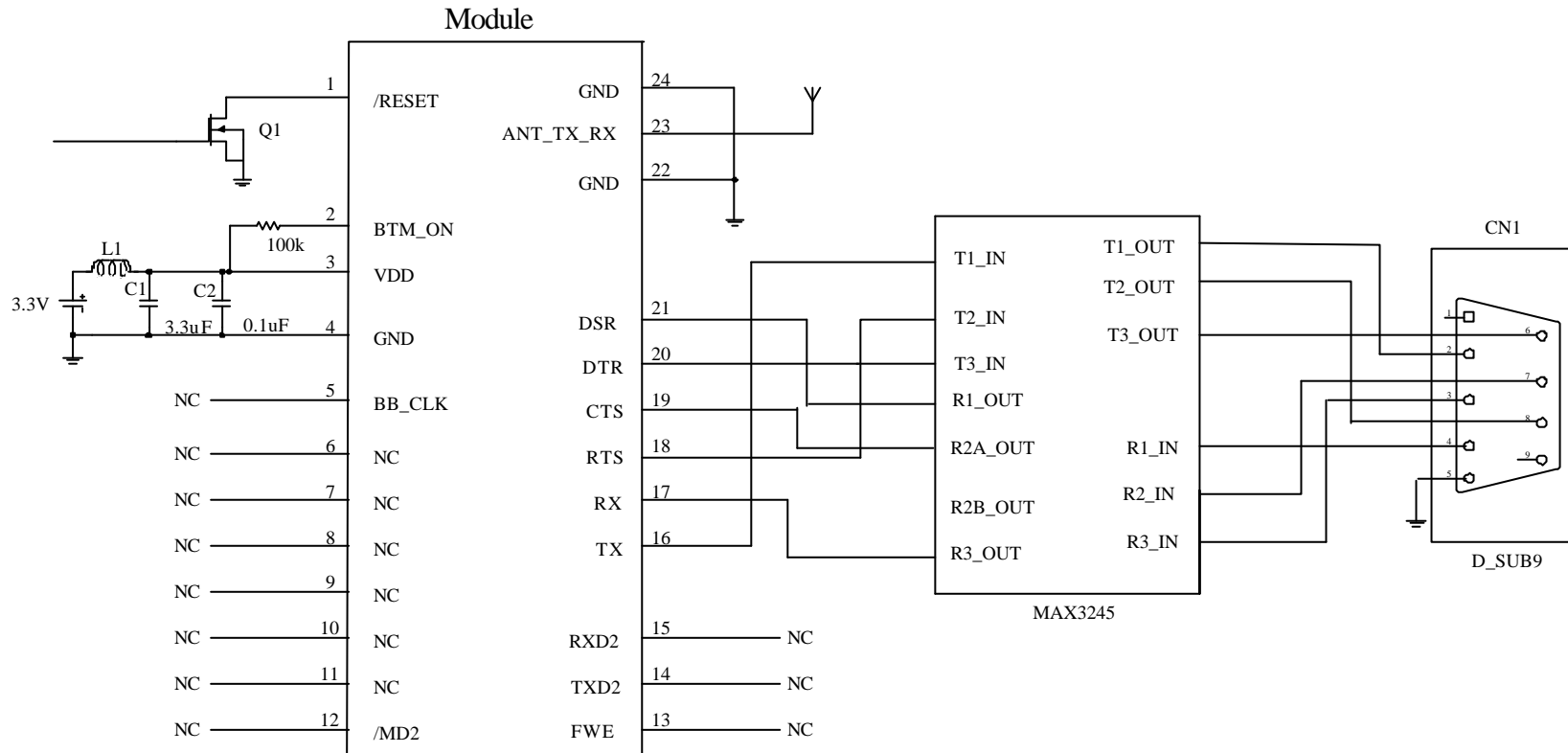

- L1: FBMH1608HM221(TAIYO YUDEN CO.,Ltd.)
- C1: LMK316BJ335K(TAIYO YUDEN CO.,Ltd.)
- C2: UMK212BJ104K(TAIYO YUDEN CO.,Ltd.)
- Q1: 2SK2158

# EYSF2SAXX

AIYOYUDEN Tentative

Control No. HD-AD-A 001111	(1/2)	Control name Outline/Appearance
-------------------------------	-------	------------------------------------

Unit:mm

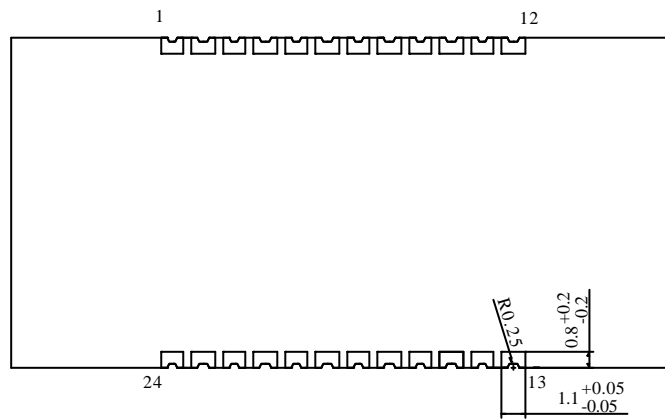
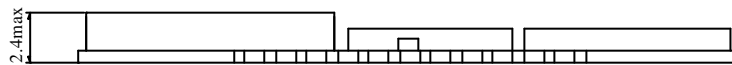
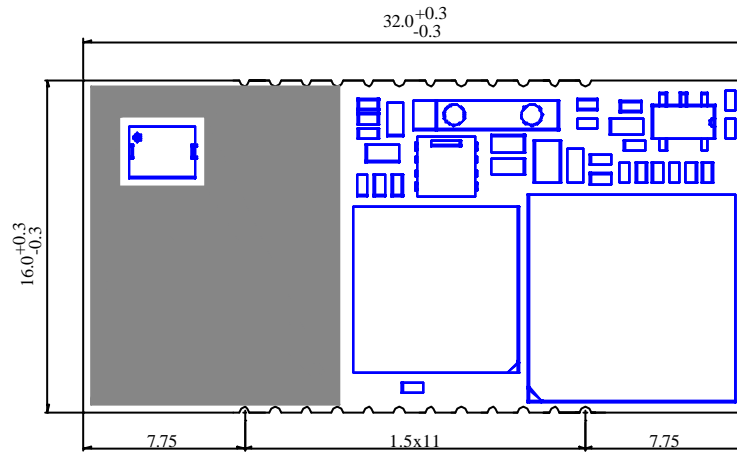

# EYSF2SAXX

AIYOYUDEN Tentative

Control No. HD-AD-A 001111	(2/2)	Control name Outline/Appearance
-------------------------------	-------	------------------------------------

## LAND PATTERN EXAMPLE

Unit:mm

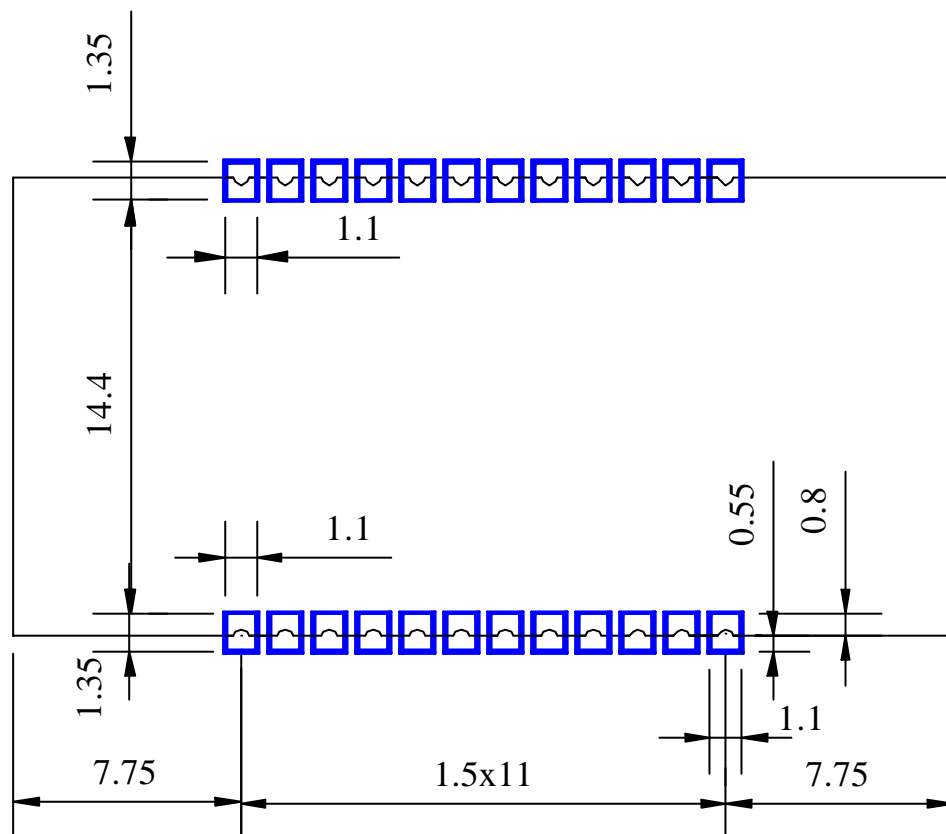

### Caution

Do not wire on mother board except ground pattern where reverse side of module to be placed.

**EYSF2SAXX**

AIYOYUDEN Tentative

Control No. HD-BA-A 001111	(1/1)	Control name Pin Layout
-------------------------------	-------	----------------------------

## Pin Descriptions

No.	Pin Name	Type	Direction	Description	Block
1	/RESET	CMOS	Input	Active low reset, see notes 1	
2	BTM_ON	CMOS	Input	When tied to VDD , the module is enabled.	
3	VDD	Power	Power	Power Supply Voltage	Power Supply
4	GND	Power	Power	Signal ground	
5	BB_CLK	CMOS	Output	Do not connect -Baseband Clock Check port	
6	NC	NC	-	Do not connect	
7	NC	NC	-	Do not connect	
8	NC	NC	-	Do not connect	
9	NC	NC	-	Do not connect	
10	NC	NC	-	Do not connect	
11	NC	NC	-	Do not connect	
12	/MD2	CMOS	Input	Do not connect -Flash ROM write port	Flash ROM Write
13	FWE	CMOS	Input	Do not connect -Flash ROM write port	
14	TXD2	CMOS	Output	Do not connect -Flash ROM write port	
15	RXD2	CMOS	Input	Do not connect -Flash ROM write port	
16	TX	CMOS	Output	TX Data, see notes 2 and 4	UART
17	RX	CMOS	Input	RX Data, see notes 4	
18	RTS	CMOS	Output	Flow control signal, Request To Send, see notes 2 and 4	
19	CTS	CMOS	Input	Flow control signal, Clear To Send, see notes 4	
20	DTR	CMOS	Output	Data terminal ready, see notes 2,3 and 4	
21	DSR	CMOS	Input	Data set ready, see notes 3 and 4	
22	GND	Power	Power	Radio Frequency Ground	RF
23	ANT_TX_RX	RF	In/Out	50 ohm Antenna connection	
24	GND	Power	Power	Radio Frequency Ground	

Note: The CMOS buffers are low voltage TTL compatible signals.

## Notes:

- 1: /RESET signal must be driven by open drain output. Pull-up resistor inside the module is 1M ohm (Typ).
- 2: These pins are internally pulled up by 1.5k ohm (Typ).
- 3: In case of not using DTR and DSR, please open DTR and pull-down DSR by 100k ohm. Sleep Mode doesn't work in this case.
- 4: The output high voltage and input high voltage of these pins listed from Pin 16 to Pin 21 is usually 3.0V.  
In case there is a mismatch of interface voltage between Host and our module, please use the level shift buffer or other proper way for these signals.

# EYSF2SAXX

AIYOYUDEN Tentative

Control No. (1/1)	Control name Reflow profile
----------------------	--------------------------------

